



**duradecor**

weekendwarrior | Peel & Stick LVT  
**Product Guide**





# **duradecor**

## **Table of Contents**

<b>Technical Data Sheet</b>	<b>3</b>
<b>General Information</b>	<b>4</b>
<b>Recommended Tool List</b>	<b>5</b>
<b>Flooring Installation Instructions</b>	<b>6</b>
<b>Flooring Installation Images</b>	<b>8</b>
<b>Wall Installation Instructions</b>	<b>9</b>
<b>Wall Installation Images</b>	<b>11</b>
<b>Maintenance Instructions</b>	<b>12</b>
<b>Product Warranty</b>	<b>13</b>

### General Specifications

Overall Product Thickness:	<b>1.5 mm</b>
Wear Layer Thickness:	<b>3 mils (0.07 mm)</b>
Product Type:	<b>Peel &amp; Stick Luxury Vinyl Tile (LVT)</b>
Product Dimensions - Tile:	<b>4" x 36", 6" x 36", 7" x 48"</b>
Finish:	<b>Scratch-Resistant Polyurethane</b>
Residential Warranty:	<b>15 years</b>
Carton Quantity - 4" x 36":	<b>20 Pieces (20 sq. ft.)</b>
Carton Quantity - 6" x 36":	<b>14 Pieces (21 sq. ft.)</b>
Carton Quantity - 7" x 48":	<b>10 Pieces (23.33 sq. ft.)</b>
Carton Weight - 4" x 36":	<b>13.51 lbs.</b>
Carton Weight - 6" x 36":	<b>13.96 lbs.</b>
Carton Weight - 7" x 48":	<b>15.43 lbs.</b>

### Technical Specifications

ASTM F1700 - Solid Vinyl Tile Specification:	<b>Class III, Type B</b>
ASTM F2055 - Size:	<b>Passes, ± 0.4 mm</b>
ASTM F387 - Product Thickness:	<b>Passes, ± 0.13 mm</b>
ASTM F2055 - Squareness:	<b>Passes, ± 0.25 mm</b>
ASTM F1914 - Residual Indentation:	<b>Passes, ≤ 0.2 mm</b>
ASTM F137 - Flexibility:	<b>Passes, 25.4 mm mandrel</b>
ASTM F2199 - Dimensional Stability:	<b>Passes, &lt; 0.5 mm / lin. ft.</b>
ASTM F925 - Chemical Resistance:	<b>Passes ASTM F1700 requirements</b>
ASTM F1514 - Resistance to Heat:	<b>Passes, &lt; ΔE 8</b>
ASTM F1515 - Resistance to Light:	<b>Passes, &lt; ΔE 8</b>
ASTM F970 - Static Load (Modified):	<b>≤ 0.13 mm indent, 1200 lbs.</b>
ASTM E648 (NFPA 253) - Critical Radiant Flux:	<b>Class 1, &gt; 0.45 W/cm<sup>2</sup></b>
ASTM E662 (NFPA 258) - Smoke Density:	<b>Passes, &lt; 450</b>
ASTM D2047 / UL 410 - Slip Resistance:	<b>&gt; 0.5 SCOF (no ramps)</b>

**Disclaimer:** These test results were independently tested, using material from standard production, in accordance with product-specific standard test methods. Physical and performance testing may vary, within tolerances, depending on the testing apparatus and/or production lot used. Be sure to use the most recently published versions of all reference documents, specifications and test methods. To purchase the most recent version of the above mentioned ASTM and ISO standards, please visit [www.astm.org](http://www.astm.org). or [www.iso.org](http://www.iso.org), respectively. Test reports are available upon request.

### Limitations

WeekendWarrior is a peel-and-stick vinyl product that is designed to be installed in residential indoor applications only. This product must be installed over an approved substrate that is properly primed with a suitable latex-based primer - failure to do so could result in adhesion issues. Avoid prolonged exposure to direct sunlight or other heat sources where temperatures will exceed 90° F (32° C), as damage or deformation may occur. Use non-rubber backed entrance matting at all outdoor entrances, as this will improve air quality and reduce maintenance. If required or concerned, immediately contact the technical department at 1-(855) 700 - 5666 or [customercare@duradecor.com](mailto:customercare@duradecor.com) for assistance.

### Warning

All local, state, and federal regulations must be followed; this includes the removal of in-place asbestos (floor covering and adhesive) and any lead-containing material. The Occupational Safety and Health Administration (OSHA) has exposure limits for people exposed to respirable crystalline silica; this requirement must be followed. Do not use solvent or citrus-based adhesive removers. When appropriate, follow the Resilient Floor Covering Institute's (RFCI) Recommended Work Practice for Removal of Existing Floor Covering and Adhesive. Always wear safety glasses and use respiratory protection or other safeguards to avoid inhaling any dust. The label, installation, and maintenance instructions along with the technical data sheet, limited warranty and any appropriate Safety Data Sheet (SDS) of all products must be read, understood, and followed before installation commences. If the substrate or subfloor fails for any reason, then the floor covering limited warranty is void.

### Site Conditions & Storage

The tile, adhesive and accessories must be stored in dry indoors conditions between 40° F - 90° F (4° C - 32° C). Do not store outside (even in containers) and do not stack pallets. The installation area must be fully enclosed and weather tight. Protect the adhesive and tile from excessive temperature fluctuations. Use permanent or temporary HVAC systems to control the site condition. The temperature must be between 60° F to 80° F (16° C to 27° C) and constant ( ±5° F) for 48-hours before, during and after the installation. The ambient relative humidity must be between 35% and 65% and 10° F above dew point, with temperatures rising – dew point calculators are available on the Internet. Failure to ensure these conditions are met could affect adhesion and product stability.

### Documentation

Record and file the measured and observed site conditions and test results, including all photographs and corrective measures. Maintaining this documentation,

along with the original invoice and any labor receipts throughout the warranty period, is recommended, as this will be required in the unlikely event of a claim.

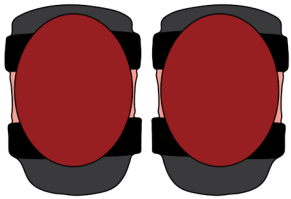

- Knee Pads
- Safety Glasses
- Cut-Resistant Safety Gloves
- Dust Mask

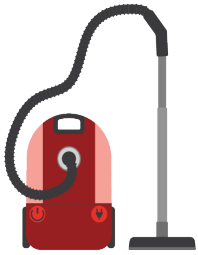

- HEPA-Filtered Vacuum
- Paint Roller & Floor/Wall Primer

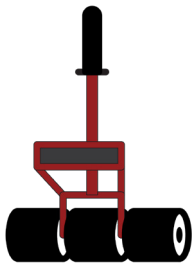

- Three-Section Wall Roller with Extendable Handle (~9 in. Wide) or Three-Section 100 lb. Floor Roller
- Pencil
- Speed Square

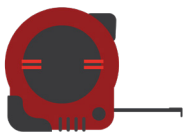

- Tape Measure
- Utility Knife with Blades



- 6-foot and 1-foot Straight Edge or Level

## 1. Floor Substrate Preparation

### Radiant Heating Substrates

When installing floor covering over a substrate that contains a radiant heating system, ensure the radiant heat does not directly contact the floor covering and is set at the correct "in-service" temperature for 48-hours prior, during and after the installation. The radiant heat may be gradually increased or decreased to maintain the correct "in-service" site conditions.

Note: Ensure the temperature of the radiant heating system does not exceed 85°F (29°C).

### Flatness

Check all substrates for flatness - all areas should be smooth and flat. The recommended flatness tolerance is < 1/8-in. gap (2 x U.S. quarters) underneath a 6-ft. straight level and < 1/16-in. gap (1 x U.S. quarter) under a 1-ft. level. Make any necessary and appropriate adjustments to the substrate before installation.

### Concrete Substrates

All concrete must be clean and free of contaminants. If required, using a moisture-resistant leveling or patching compound, following the product instructions. Do not install if hydrostatic pressure is visible, present or suspected. If a chemical adhesive remover has been used, contact the technical department.

All concrete slabs must be (and remain) surface dry and at least 28-days old. Refer to the primer manufacturer's instructions regarding concrete substrate preparation.

### Wood Substrates

All wooden subfloors and substrates must be dry and in compliance with all federal, state and local building codes, have at least 18-in. of well-ventilated air space below. If necessary, install an underlayment grade plywood with a minimum thickness of 1/4-in. on the surface. The underlayment must be installed in the opposite direction to the subfloor, following the product instructions. Refer to the primer manufacturer's instructions regarding wood substrate preparation.

Note: Plywood is porous, therefore the seams may telegraph through any flexible resilient flooring, due to the natural expansion and contraction from humidity changes. This is not covered by the product limited warranty.

### Gypsum Substrates

All gypsum substrates must be smooth, flat, dry, structurally sound, firmly bonded to the subfloor and free of contaminants. Refer to the primer manufacturer's instructions regarding gypsum substrate preparation.

### Hard-Surface Substrates

All hard-surface tile, such as ceramic, porcelain or marble tile, must be patched with a moisture-resistant leveling or patching compound, following the product instructions. All grout lines must be filled, smooth and flush with the surface of the tile, in order to prevent telegraphing and adhesion issues.

### Unsuitable Substrates

These include, but are not limited to: any floating or loose floor coverings, hardwood, carpet, cushion vinyl, rubber, cork, foam, asphalt tile; any substrate with visible mold, mildew, or fungi and any substrate in wet areas, such as inside showers and saunas; substrates that have been coated with a varnish or oil-based, enamel, paint, primer-sealer or stain-blocker; and substrates made of Masonite™, chipboard, wafer board, fiberboard, particleboard, construction-grade plywood, CDX, OSB (including AdvanTech™), Luan, cement board or any non-underlayment grade panels must be removed and replaced or covered with an underlayment grade plywood. Do not use pressure-treated or fire-retardant plywood. Do not install directly over adhesive residue. Do not install in recreation vehicles, campers or boats.

Note: Electing to install over any existing floor covering releases the manufacturer from any responsibility regarding the suitability and continued performance of the product, including any resulting effect on the new floor covering, such as indentations and adhesive failure.

### Other Subfloors/Substrates

These may be acceptable. However, they must be smooth, flat and remain dry, without contaminants and be structurally sound.

## 2. Floor Installation Instructions

### Acclimation

Depending on the temperature of the floor covering, an extended acclimation period may be required. Check the temperature of the floor covering using a non-contact, infrared thermometer - the floor covering must be at the same temperature as the required site conditions ( $\pm 2^\circ$  F) before installation.

### Layout

Determine the ideal installation pattern and direction. Measure the width of each end of the area, then calculate and mark your starting line with a pencil, which should be near the center of the room (see figure 1). Calculate the width of the last row - if it is less than half the width of the floor covering, adjust your starting line by half the width of the flooring. Make sure all pencil markings are bold and clear so that they can be seen through the primer - do not use

a pen or permanent marker. It is recommended that plank end joints be staggered randomly by at least 8 in. to avoid an undesirable "stair stepped" or "H joint" pattern (see figure 2). Tiles are recommended to be installed either in a brick-bond or a 1/3rd off-set pattern.

### Priming & Cleaning

Clean the substrate using a HEPA filtered vacuum, then apply the first coat of a suitable latex-based flooring primer (not included), following the product instructions (see figure 3). The selected primer must be designed for use with self-adhering vinyl flooring. Once the first coat of the primer has dried, apply a second coat of primer in a perpendicular direction to the first coat and allow to dry. Clean the primed substrate directly before flooring installation using a HEPA filtered vacuum.

### Grouting

If the product has a micro-beveled edge, the flooring may be grouted. During installation, leave a consistent gap around all four sides of the tile or plank – the gap should be created using appropriate tile spacers and should be 1/16-in., 1/8-in. or 3/16-in. wide. Remove the spacers just before rolling and grout the joints using a flexible grout specifically made for vinyl floor covering. Follow the product instructions regarding its application and cleaning.

Note: Any grout residue left on the surface will affect product maintenance and is not covered under the warranty.

### Cutting

To cut the floor covering, measure and mark the surface with a pencil, then carefully score the surface a few times using a sharp utility knife along the side of a speed square (see figure 4). Snap the piece downwards to complete cut.

### Installation

Mix floor covering from several boxes to ensure a consistently random appearance. During the installation, inspect each piece for visible defects, including damage, gloss, color, or shade variations. Do not install any floor covering with visible defects or damage, as removal, subfloor repair and replacement labor costs will not be covered.

Remove the release paper on the bottom of the floor covering and discard immediately in a trash can or bag (see figure 5). Follow the layout and starting line and carefully position each piece accordingly, keeping all joints snug without compressing the material. Check to ensure the starting row is straight - the acceptable straightness tolerance is within 1/16-in. for lengths over 20-ft. or 1/32 in. for lengths under 20-ft.

After the first installation section is completed, roll the entire area slowly, across the width then length, using a wall/laminating three-section roller with extendable handle and your body weight or a 100 lb. three-section roller (see figure 6). Failure to roll correctly may result in bond failure.

Repeat this process for the remainder of the installation. Remove all adhesive from the surface using a small amount of 70% Isopropyl alcohol and a clean cloth.

### Protection

For furniture, use only polyurethane, silicon or felt glides (replaced > 3-times a year), keeping them clean and grit-free – all glides should be  $\geq 1\text{-in.}^2$ , especially on heavy furniture. Use chair mats underneath rolling chairs or soft "W-type" wheels. Use non-rubber-backed entrance matting at all outdoor entrances, as this will improve air quality and reduce maintenance. Do not drag heavy or sharp objects directly across the surface - use hard surface "sliders" (available at Hardware stores). For areas that may be subjected to standing water on the surface, such as bathrooms with a bath or shower, the perimeter of the installation must be properly sealed using a 100% silicon caulk to prevent water from getting beneath the flooring. To avoid excessive fading or discoloration from direct sunlight exposure, use appropriate window treatments.

Figure 1: Layout - Mark the starting line

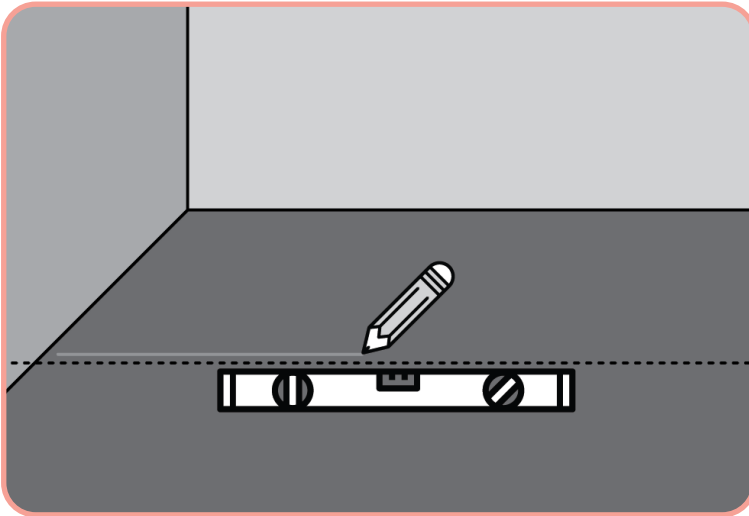

Figure 4: Cutting - Mark, score & snap downward

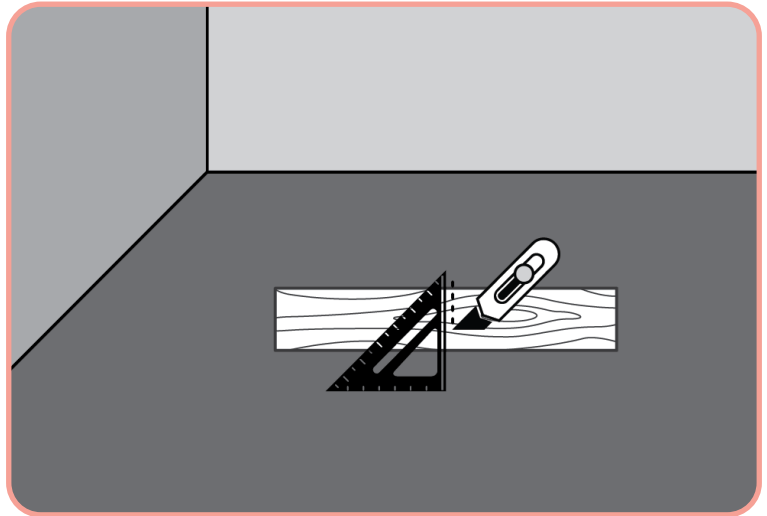

Figure 2: Layout - Stagger seams

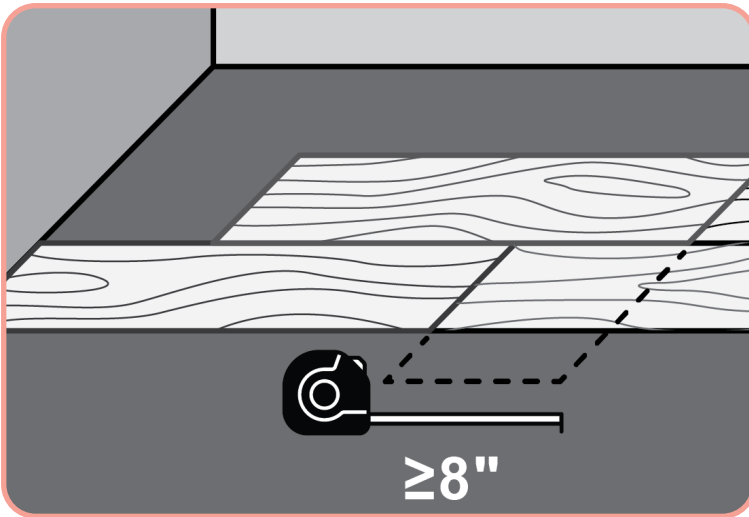

Figure 5: Installation - Remove release paper

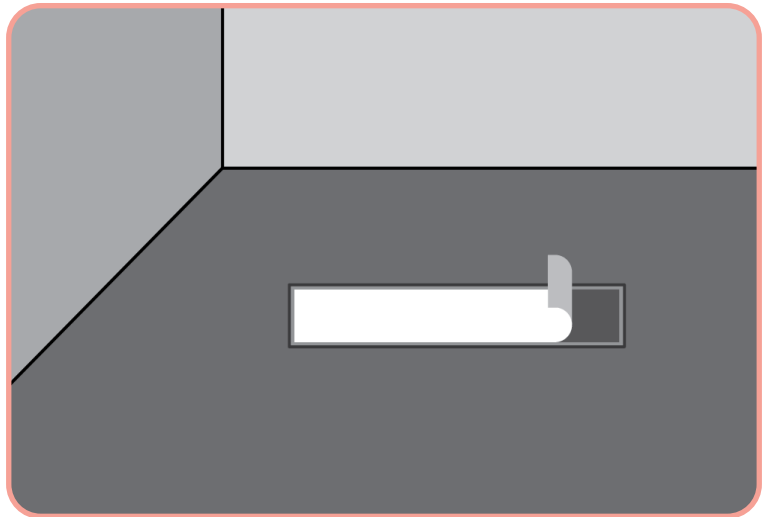

Figure 3: Priming & Cleaning - Prime substrate

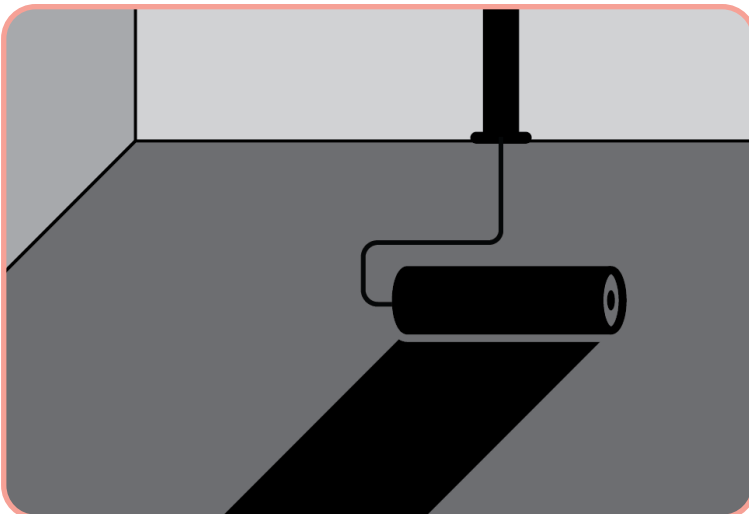
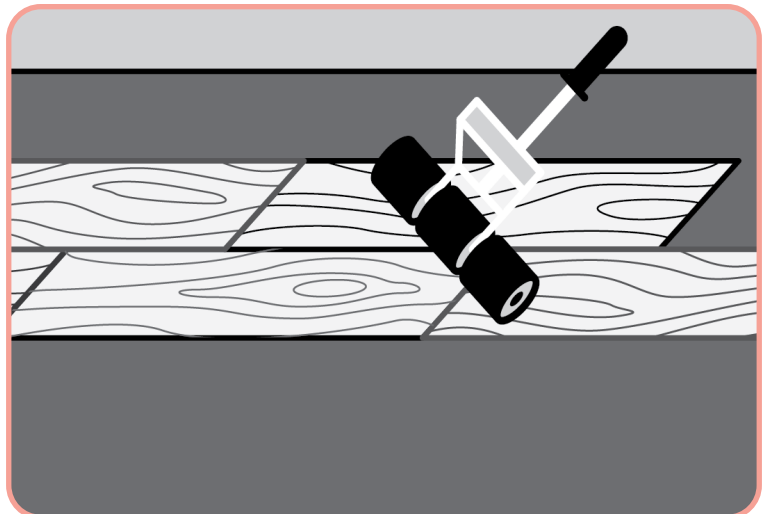

Figure 6: Installation - Roll flooring with roller





## 1. Wall Substrate Preparation

### Flatness

Check all substrates for flatness - all areas should be smooth and flat. The recommended flatness tolerance is < 1/8-in. gap (2 x U.S. quarters) underneath a 6-ft. straight level and < 1/16-in. gap (1 x U.S. quarter) under a 1-ft. level. Make any necessary and appropriate adjustments to the substrate before installation.

### Drywall Substrates

All drywall substrates must be smooth, flat, dry, structurally sound, firmly anchored to studs and free of contaminants. All seams, holes, cracks, and other voids in all existing drywall substrates must be filled with an appropriate gypsum-based patch or joint compound and sanded smooth. New or repaired drywall must be primed using a suitable PVA primer and allowed to fully dry/cure before installation.

New plaster walls and paint must be at least 30 days old, to allow for proper curing. Clean new plaster with diluted vinegar and water (1-1) and allow to dry.

Existing painted walls must be lightly sanded using fine sandpaper or steel wool, then wiped clean with a damp cloth and allowed to dry prior to installation. Dirt and grease must be removed by washing with a suitable detergent and warm water, then be allowed to dry.

### Unsuitable Substrates

Do not install tile over wallpaper, wall coverings, wall panels, flaking paint, adhesives or any other unstable and/or unsuitable material. These include, but are not limited to: hardwood, rubber, cork and foam; any substrate with visible mold, mildew, or fungi and any substrate in wet areas, such as inside showers and saunas; substrates that have been coated with a varnish or oil-based, enamel, paint, primer-sealer or stain-blocker; and substrates made of Masonite™, chipboard, wafer board, fiberboard, particleboard, mahogany-based plywood, construction-grade plywood, CDX, OSB (including AdvanTech™), Luan, fiberglass-reinforced plastic panels (FRP), cement board, CMU, brick and mortar. Any non-underlayment grade panels must be removed and replaced or covered with a suitable product. Do not use pressure-treated or fire-retardant plywood. Do not install directly over adhesive residue. Do not install in recreation vehicles, campers or boats.

Note: Electing to install over any existing wall covering releases the manufacturer from any responsibility regarding the suitability and continued performance of the product, including any resulting effect on the new floor covering, such as indentations and adhesive failure.

## 2. Floor Installation Instructions

### Acclimation

Depending on the temperature of the floor covering, an extended acclimation period may be required. Check the temperature of the floor covering using a non-contact, infrared thermometer - the floor covering must be at the same temperature as the required site conditions ( $\pm 2^\circ$  F) before installation.

### Layout

Determine the ideal installation pattern and direction - it is recommended that the installation pattern be balanced, with equal tile sizes around the entire perimeter. Measure the width of each end of the area, then calculate and mark your starting line with a pencil, which should be near the center of the wall (see figure 1). Calculate the width of the last row - if it is less than half the width of the tile, adjust your starting line by half the width of the tile. Make sure all pencil markings are bold and clear so that they can be seen - do not use a pen or permanent marker. It is recommended that plank end joints be staggered randomly by at least 8 in. to avoid an undesirable "stair stepped" or "H joint" pattern (see figure 2). Tiles are recommended to be installed either in a brick-bond or a 1/3rd off-set pattern.

### High-Heat Equipment & Electrical Connections

Do not install within 4-in. (10-cm) of any heat source, such as boilers, wall-mounted exchangers or radiators and baseboard heating systems. Ensure that open ranges and cook-tops are at least 8-in. (20-cm) away from the installation. Ensure all enclosed ovens, stoves, toasters, toaster ovens, fryers, and other high-heat cooking equipment are at least 2-in. (6-cm) away from the installation.

The power supply to all electrical outlets, light switches and other electrical fixtures in the installation area should be turned off at the main junction box so that all outlet and light switch cover plates can be safely removed. All tiles must be cut to fit around all junction boxes so that all cut edges are covered by the cover plate. Any associated electrical work must be performed by a qualified electrician.

### Cutting

To cut the floor covering, measure and mark the surface with a pencil, then carefully score the surface a few times using a sharp utility knife along the side of a speed square (see figure 3). Snap the piece downwards to complete cut.

### Installation

Mix tile from several boxes to ensure a consistently random appearance. During the installation, inspect each piece for visible defects, including damage, gloss, color, or shade variations. Do not install any floor covering with visible defects or damage, as removal, subfloor repair and

replacement labor costs will not be covered.

Remove the release paper on the bottom of the tile and discard immediately in a trash can or bag (see figure 4). Follow the layout and starting line and carefully position each piece accordingly, keeping all joints snug without compressing the material (see figure 5). Check to ensure the starting row is straight - the acceptable straightness tolerance is within 1/16-in. for lengths over 20-ft. or 1/32 in. for lengths under 20-ft.

After the first installation section is completed, roll the entire area slowly, across the width then length, using a three-section wall roller with extendable handle and your body weight (see figure 6). Failure to roll correctly may result in bond failure. Repeat this process for the remainder of the installation. Remove all adhesive from the surface using a small amount of 70% Isopropyl alcohol and a clean cloth.

When finished, replace any wall trim, cove base, or moldings. If hanging pictures or other objects on the wall after installation, pre-drill through the tile to avoid damage.

Figure 1: Layout - Mark the starting line

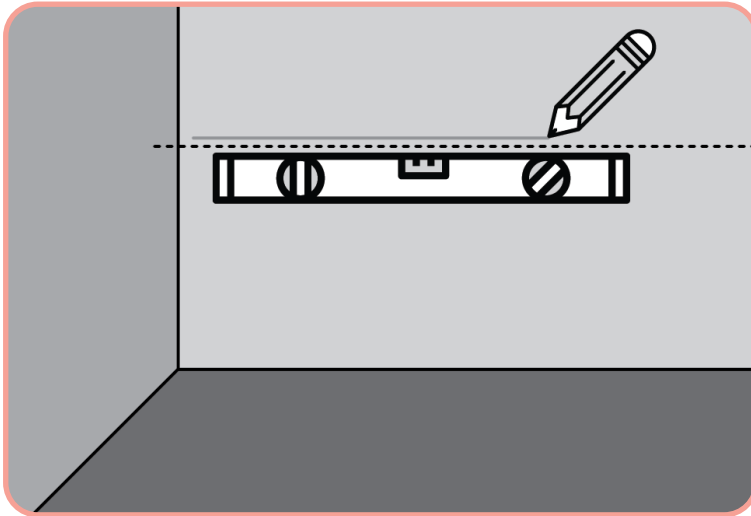

Figure 4: Installation - Remove release paper

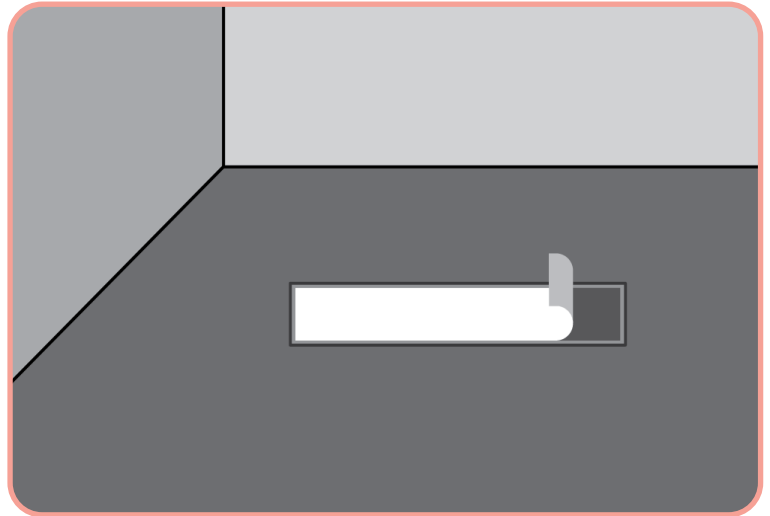

Figure 2: Layout - Stagger seams

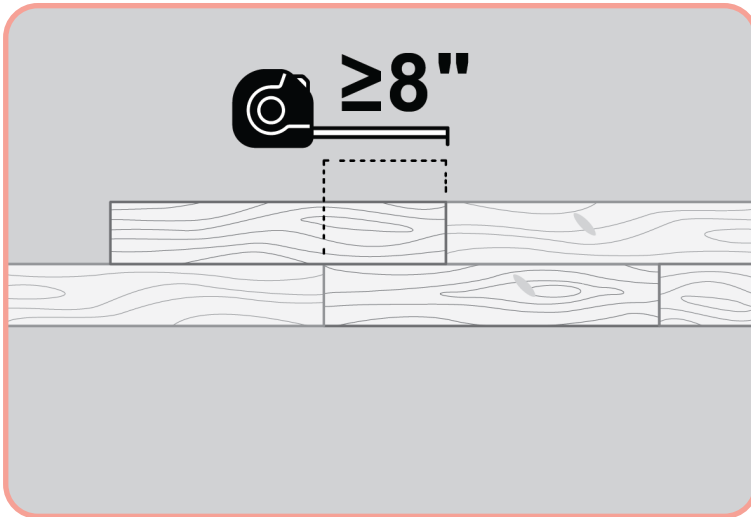

Figure 5: Installation - Install along starting line

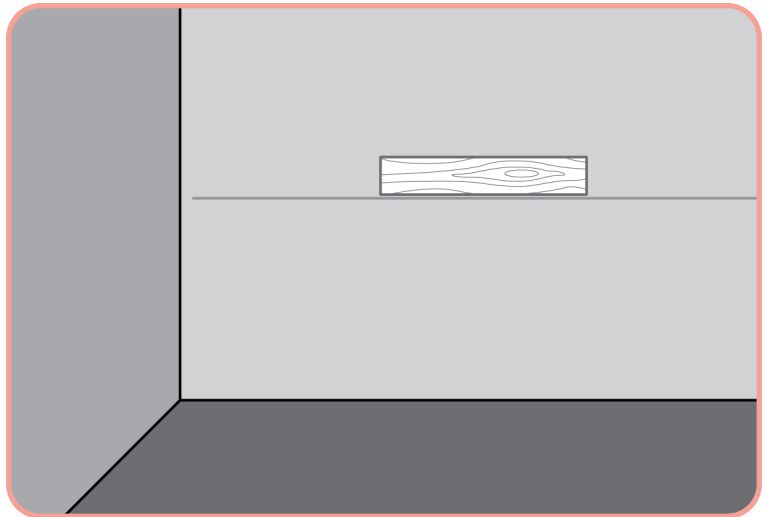

Figure : Cutting - Mark, score & snap downward

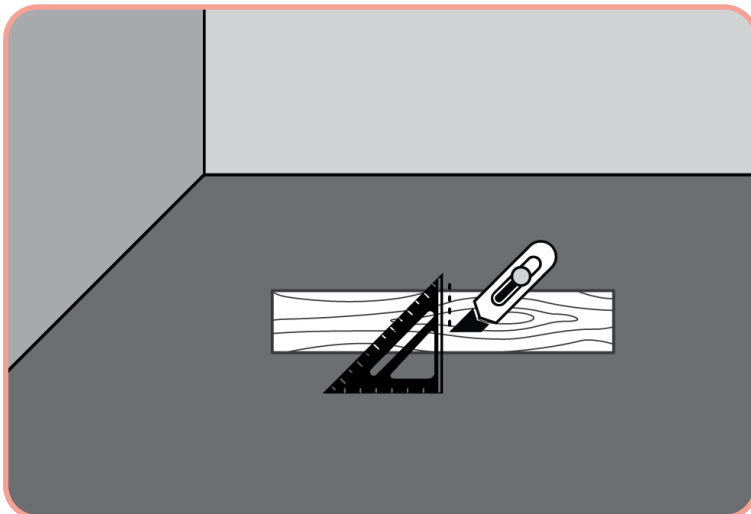
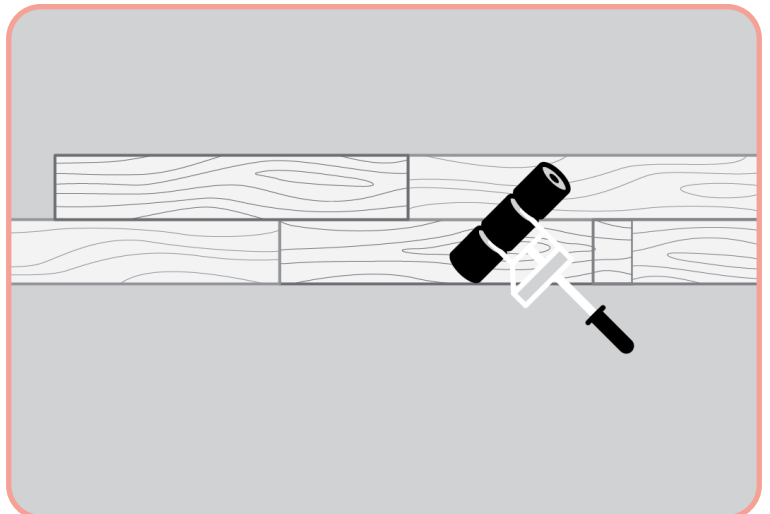

Figure 6: Installation - Roll flooring with roller



## 1. Precautions

Do not perform any maintenance procedures on wall installations for 72-hours. Remove all metal objects before conducting maintenance and prohibit foot traffic until the floor is dry. Do not use dust mops treated with oils or silicones, acetone, strong alkaline cleaning agents, multi-surface cleaners, vinegar/ammonia/ citrus oil solutions, scouring powder, strong solvents, or abrasive cleaning pads, as these can damage the flooring. Do not wet mop or allow cleaning solutions to puddle or pool on the surface of the material. The application of a floor-finish is not recommended and will change the maintenance protocol.

## 2. Regular Cleaning

Wipe, dust-mop or vacuum the material to remove any dirt or grit – do not use a vacuum with a beater bar. Damp-mop or wipe the material as often as required using a clean cloth, a flat microfiber mop or a spray mop or a flat microfiber spray mop. Use a pH neutral, film-free and streak-free cleaner concentrate (diluted with potable water), available at local hardware stores. Make sure to change the cloth or mop pad as often as required.

## 1. General Terms

Novalis Innovative Flooring ("Manufacturer") warrants that, when used properly and under normal operating conditions, the products described in the Manufacturer's catalog as WeekendWarrior Peel and Stick Luxury Vinyl Wall and Floor Tile ("Product"), a 1.5mm glue down vinyl tile. The Product is a Luxury Vinyl floor covering (LVT/LVP) that is pre-coated with a hot-melt adhesive. The Product will conform to the published Product technical documents. All installation outside of these parameters shall void this Limited Warranty.

This Limited Warranty is not transferable and only applies to the original end-user ("Customer") of the Product. This Limited Warranty does not apply to Product that has been sold or resold as "seconds", "mill-run", "off goods", "non-conforming", "as-is", "closeouts" or otherwise denoted as irregular, non-first or non-standard quality.

The Manufacturer's liability and Customer's exclusive remedy under this Limited Warranty is limited to the replacement or refund of the defective Product and, only if without visible and obvious (> 0.5-inch) defects will the Manufacturer include reasonable labor costs for the geographic region. This Limited Warranty does not include other costs associated with installation or removal of the defective Product or installation of the replacement Product including, but not limited to, lost time, furniture removal and/or overtime pay. Only one replacement floor or refund shall be made. A Customer who received a settlement may not make another claim - no additional replacement floors or refund will be supplied.

If the Manufacturer no longer provides the particular Product subject to this Limited Warranty, Manufacturer reserves the right to substitute another Product that Manufacturer deems to be comparable or superior in its place. Manufacturer's responsibility to replace defective Product under this Limited Warranty applies only to the affected area of Product so long as a suitable match (as determined and at the sole discretion of Manufacturer) can be supplied. Full replacement or replacement of a greater area than the affected area is at the sole discretion of Manufacturer. Manufacturer reserves the right to provide replacement materials directly to the Customer, or through a professional installation company of the Manufacturer's choice, to conduct repairs or replace materials in a manner suitable to the Manufacturer's interests.

This Limited Warranty is specific to the Product which shall be installed, used, maintained and cared for in accordance with the Product documentation, which may be obtained at [www.duradecor.com](http://www.duradecor.com) or are available upon request by contacting [customercare@duradecor.com](mailto:customercare@duradecor.com) or 1 - (855) 700 - 5666.

## 2. Warranty Terms & Provisions

**2.1. Manufacturing Defect Term:** The Product shall be free of manufacturing defects for a period of 1-year from the Customer date of purchase. All claims must be reported within thirty (30) days of discovery of the defect.

**2.2. Wear Warranty Term:** "The Product", when installed and maintained as detailed within the instructions, will not wear-through to the printed film layer under normal use for 15 years from date of purchase.

**2.3. Wear Warranty Provisions:** Stains from unapproved chemicals, fading, scratches, scuffs, and loss of gloss are considered normal use and are not covered under this warranty. The Manufacturer will supply new material of the same color, design, and grade, if available; if unavailable or discontinued, the Manufacturer reserves the right to supply similar floor covering. After corrective action is taken on an existing defect, Limited Warranty coverage will remain in effect for the remaining Wear Warranty Term of the original Limited Warranty.

Alternatively, at the Manufacturer's discretion, a refund of the original cost of the Product shall be used to settle all other valid claims according to the following pro-rated schedule:

### Residential Wear Coverage:

≤ 2 years:	100%
≤ 10 years:	70%
> 10 years:	50%
> 15 years:	0%

**2.4. Labor Warranty Term & Provisions:** Labor costs shall not be reimbursed for all material installed with visible and obvious (> 0.5-inch) defects. Reasonable costs of professional labor for replacement must be submitted to and pre-approved by the Manufacturer. The percentage of labor costs that shall be reimbursed is according to the following pro-rated schedule:

### Residential Labor Coverage:

≤ 2-years:	100%
≤ 10-years:	50%
> 10-years:	0%

**2.5. Waterproof Warranty:** The Product will not be materially impaired when exposed to wet or damp cleaning, surface spills and/or tracked in water for the length of the Wear Warranty. This does not include water emergencies.

**2.6. Petproof Warranty:** The Product surface coating provides scratch and stain resistance (such as feces, urine and/or vomit) from domestic household pets, such as cats and dogs, provided that pet claws are routinely cut and filed.

### 3. Warranty Terms & Provisions

This Limited Warranty does not apply to nor cover nonconformities that are caused by, result from or arise in connection with any of the following conditions:

Non-Compliance with applicable Product requirements and technical data. Any Product that has been subjected to site conditions, substrate conditions, installation methods, maintenance procedures and/or conditions of use that are not in strict conformity with the associated Technical Data Sheets, Installation Instructions, Maintenance Documents and any other relevant technical documents.

Non-Compliance with applicable industry guidelines. Substrate preparation must be performed in accordance with all related ACI, ASTM, NAWFA and RFCI guidelines.

Installation of Product with any third-party adhesive not explicitly recommended or approved by Novalis Innovative Flooring. The use of unapproved adhesives excludes any warranty coverage of adhesive performance issues, including but not limited to bond strength, shrinkage, expansion, peaking, ledging, curling, doming and/or the ability of the adhesive to control the dimensional stability of the floor covering. This also excludes any associated material and labor costs associated with third-party adhesives.

Installation of Product with unapproved installation materials, methods or tools, including but not limited to the recommended underlayment type, repair products and all accessories.

Cracking, warping, delamination, curling, or other phenomena caused by excessive heat sources, such as prolonged direct sunlight, radiators, self-cleaning ovens and high-heat equipment.

Fading or discoloration of the surface due to excessive UV/IR exposure.

Stains from tracked carpet dyes, fertilizers, coal, tar, driveway sealers, oil, permanent markers, or other such contaminants.

Substrate failure, movement or imperfections, including improper flatness, smoothness or damage.

Hazing or finish-related issues caused by the grout and or residue when used with the Product.

Heavy static loads (>1,500 lbs.) and heavy point loads, such as foot traffic with stiletto heels, spikes or skates, dropped items, improper floor protectors and furniture feet/rests or floor protection and furniture feet/rests that do not make adequate flat contact with the floor covering.

Heavy rolling loads (> 1,500 PSI) with metal wheels, hard

H-type wheels or any other wheel types that do not make adequate, flat contact with the floor covering.

Damage caused by mechanical issues, intentional abuse, misuse, negligence, structural damage, seismic activity, flooding, fires, and other emergencies, natural disasters or any circumstances beyond the reasonable control of the Seller.

Damage or excessive wear caused by improper maintenance dirt, grit, and abrasive debris from not using appropriate walk-off mats at all outdoor entrances.

Any resulting health issues or property damage resulting from organic growth resulting from any type of water trapped beneath the floor covering and the latent organic material found within it, which may sponsor organic growth, such as mold, mildew, and fungi.

Normal shade, color, gloss/sheen, or embossing texture variation, including variations between installed flooring and physical flooring samples or printed marketing materials.

Excessive moisture and alkalinity from the subfloor or substrate.

Excessive topical water caused by broken or leaking plumbing, structural leaks, sink overflow, flooding, weather conditions and other water emergencies.

Installations removed or replaced prior to inspection by an authorized Novalis representative.

### 4. Slip Resistance Warning

Walking is an enormously complex activity involving many muscles, bones and nerves, as well as kinesthetic sensory information. There are several significant factors that directly affect slip resistance properties, such as the type, texture and surface structure of floor covering, surface contaminants, type of shoe soles and the walker's weight, age, gait, fitness level, awareness, and vision. There are no published requirements or acceptable limits for Static Coefficient of Friction (SCOF) or Dynamic Coefficient of Friction (DCOF) values within the resilient flooring industry, though there may be for other flooring types. While independent test results are available, that does not purport to address any safety concerns of slip resistance, the accuracy of all test methods, safety thresholds, or the measuring apparatus' (tribometers). This includes factors outside of the reasonable control of the Manufacturer, such as Product maintenance. No warranty for any slip resistance properties can be provided.

Note: Walking on any vinyl floor covering in socks or similar is not recommended, especially on stairs.

### 5. Warranty Claims

If, within the applicable warranty period identified in Article 2.1 and 2.2, the Customer discovers any problems or defects in the Product that may be covered by this Limited Warranty, the Customer must notify the distributor

or the Manufacturer directly at 1-(855) 700 - 5666 or [customercare@duradecor.com](mailto:customercare@duradecor.com). All claims must include a completed claim form, along with any associated photos, invoices, pre-installation testing reports and all independent inspection reports conducted after problems or defects are observed or suspected.

All claims must be reported within thirty (30) days of discovery of the problem or defect. If Manufacturer determines that the Product is covered by this Limited Warranty, then Manufacturer shall, at its sole option, replace the nonconforming Product or refund the appropriate percentage of the purchase price and labor cost paid for each defective Product for the affected area, per the associated pro-rated schedule. No warranty claims will be processed if received more than thirty (30) days after the applicable warranty period has ended.

Manufacturer or its designated representative shall have the right to examine the Product and the flooring, including the right to test the flooring and/or substrate at the installation site, with respect to any Product that is the subject of a warranty claim. Any removal of installed Product prior to such examination will void any and all warranties. Manufacturer may require additional testing or verification of any tests conducted or obtained by the Customer.

## 6. Warranty Disclaimer

**The warranties set forth herein are exclusive and in lieu of all other warranties or representations, express or implied, arising by law or custom, including the implied warranties of merchantability and fitness for a particular purpose. No agent, sales representative, dealer, distributor, contractor, installer, architect or designer has the authority to increase or alter seller's obligations under this warranty. This Limited Warranty does give you specific legal rights; you may also have other rights, which may vary from state to state.**

## 7. Limitation of Liability

**The aggregate cumulative total liability of Manufacturer hereunder, whether for breach of warranty or contract, indemnification, tort (including negligence), or otherwise, shall not exceed the original purchase price of the nonconforming Product. Manufacturer assumes no liability for labor costs in the installation or replacement of any Product with visible and obvious (> 0.5-inch) defects. In no event shall Manufacturer be liable to Customer or any other person for loss of revenue, profit or any consequential, incidental, exemplary or punitive damages directly or indirectly arising from the use of the Product, from breach of any warranty or from any other cause, whether or not Manufacturer has been informed of the possibility of such damages.**